

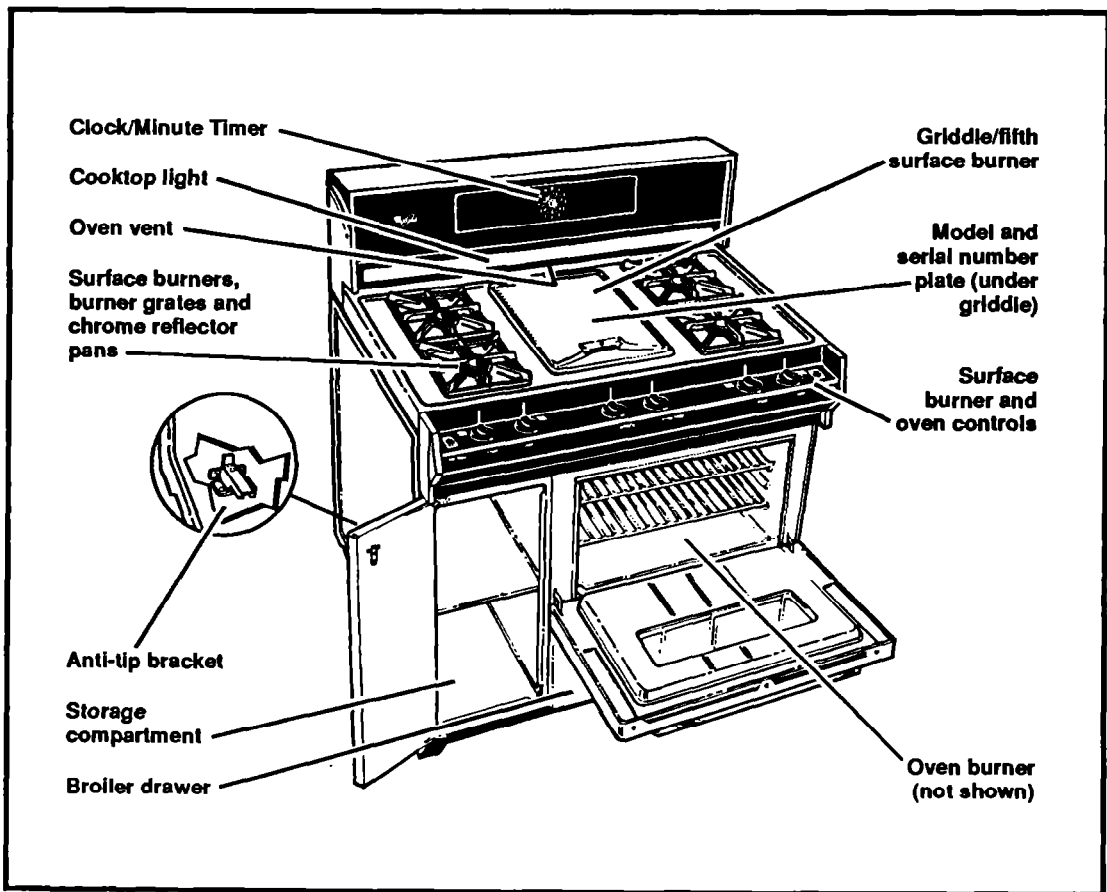

# Use & Care Guide



**STANDARD-CLEANING GAS RANGE  
SF5140EY**

# Contents

	Page
<b>Important Safety Instructions</b> .....	3
<b>Using Your Range</b> .....	6
Using the surface burners .....	6
Setting the clock .....	7
Using the Minute Timer .....	7
Using the oven control .....	8
Baking/roasting .....	8
Adjusting the oven temperature control .....	9
Broiling .....	10
Using the griddle or fifth surface burner .....	11
Using the fifth surface burner .....	12
The oven vent .....	12
<b>Caring For Your Range</b> .....	13
Control panel and knobs .....	13
Surface burner grates, reflector pans and griddle .....	14
Surface burners .....	15
Removable cooktop .....	15
Removable oven door .....	16
Using the standard-cleaning oven .....	17
Cleaning tips .....	18
Using and replacing the light bulbs .....	19
The cooktop light .....	19
The oven light .....	20
<b>If You Need Service Or Assistance</b> .....	21
<b>Whirlpool Cooking Product Warranty</b> .....	24

©1991 Whirlpool Corporation

---

**Thank you for buying a Whirlpool appliance. Please complete and mail the Owner Registration Card provided with this product. Then complete the form below. Have this information ready if you need service or call with a question.**

- Copy model and serial numbers from plate (located under griddle) and purchase date from sales slip.
- Keep this book, the Cooking Guide and sales slip together in a handy place.

---

**Model Number**

---

**Serial Number**

---

**Purchase Date**

---

**Service Company Phone Number**

**You are responsible for:**

- Installing and leveling the range on a floor strong enough to support its weight, and where it is protected from the elements. (See the Installation Instructions.)
- Making sure the range is not used by anyone unable to operate it properly.
- Properly maintaining the range.
- Using the range only for jobs expected of a home range.
- Making sure the range is secured by a properly installed anti-tip bracket.

# Important Safety Instructions

Gas ranges have been thoroughly tested for safe and efficient operation. However, as with any appliance, there are specific installation and safety precautions which must be followed to ensure safe and satisfactory operation.

## **⚠ WARNING**

To reduce the risk of fire, electrical shock, injury to persons, or damage when using the range, follow basic precautions, including the following:

### • FOR YOUR SAFETY •

**DO NOT STORE OR USE GASOLINE OR OTHER FLAMMABLE VAPORS AND LIQUIDS IN THE VICINITY OF THIS OR ANY OTHER APPLIANCE. THE FUMES CAN CREATE A FIRE HAZARD OR EXPLOSION.**

### • FOR YOUR SAFETY •

**IF YOU SMELL GAS:**

- 1. OPEN WINDOWS.**
- 2. DON'T TOUCH ELECTRICAL SWITCHES.**
- 3. EXTINGUISH ANY OPEN FLAMES.**
- 4. IMMEDIATELY CALL YOUR GAS SUPPLIER.**

**IMPROPER INSTALLATION, ADJUSTMENT, ALTERATION, SERVICE OR MAINTENANCE CAN CAUSE INJURY OR PROPERTY DAMAGE. REFER TO THIS MANUAL. FOR ASSISTANCE OR ADDITIONAL INFORMATION CONSULT A QUALIFIED INSTALLER, SERVICE AGENCY, MANUFACTURER (DEALER) OR THE GAS SUPPLIER.**

### - IMPORTANT -

**TO THE INSTALLER: PLEASE LEAVE THIS INSTRUCTION BOOK WITH THE UNIT.**

**TO THE CONSUMER: PLEASE READ AND KEEP THIS BOOK FOR FUTURE REFERENCE.**

## Important Safety Instructions Continued

- Install or locate the range only in accordance with the provided Installation Instructions. It is recommended that the range be installed by a qualified installer. The range must be properly connected to the proper gas supply and checked for leaks. The range must also be properly connected to electrical supply and grounded.



- To reduce the risk of tipping of the appliance, the appliance must be secured by a properly installed anti-tip bracket. To check if the bracket is installed properly, shine a flashlight under range toward left rear corner and verify that the anti-tip bracket is engaged. See Installation Instructions for further details.
- Gas fuels and their use in appliances can cause minor exposures to benzene, formaldehyde, carbon monoxide and soot, primarily from incomplete combustion. Significant exposure to these substances can cause cancer or reproductive harm. Properly adjusted burners with a blue, rather than a yellow, flame will minimize incomplete combustion. Venting with a hood or an open window will further minimize exposure.
- Do not operate the range if it is not working properly, or if it has been damaged.
- Do not use the range for warming or heating the room. Persons could be burned or injured, or a fire could start.
- Do not attempt to light the oven burner during a power failure. Personal injury could result.
- Use the range only for its intended use as described in this manual.
- Do not wear loose or hanging garments when using the range. They could ignite if they touch a hot surface burner and you could be burned.
- Do not touch surface burners, areas near burners or interior surfaces of oven. Areas near surface burners and interior surfaces of an oven become hot enough to cause burns. During use, do not touch, or let clothing or other flammable materials contact surface burners, areas near surface burners or interior surfaces of oven. Other surfaces of the range may become hot enough to cause burns; such as, the oven vent opening, the surface near the vent opening, the cooktop, the oven door and window.
- Make sure the utensils you use are large enough to contain food and avoid boil-overs and spill-overs. Heavy splattering or spill-overs left on a range can ignite and burn you. Pan size is especially important in deep fat frying.
- Turn pan handles inward, but not over other surface burners. This will help reduce the chance of burns, igniting of flammable materials, and spills due to bumping of the pan.
- Use only dry potholders. Moist or damp potholders on surface burners may result in burns from steam. Do not let potholder touch surface burners. Do not use a towel or bulky cloth for a potholder. It could catch on fire.
- Check to be sure glass cooking utensils are safe for use on the range. Only certain types of glass, glass-ceramic, ceramic, earthenware or other glazed utensils are suitable for ranges without breaking due to the sudden change in temperature.

- Do not use decorative covers or trivets over the surface burners.
- Do not heat unopened containers. They could explode. The hot contents could cause burns and container particles could cause injury.
- Grease is flammable and should be handled carefully. Let fat cool before attempting to handle it. Do not allow grease to collect around cooktop or in vents. Wipe spill-overs immediately.
- Do not use water on grease fires. Never pick up a flaming pan. Smother flaming pan on range by covering with a well-fitted lid, cookie sheet or flat tray. Flaming grease outside of pan can be extinguished with baking soda or, if available, a multipurpose dry chemical or foam-type extinguisher.
- Never leave surface burners unattended at high heat settings. A boil-over could result and cause smoking and greasy spill-overs that may ignite.
- Make sure surface burners are off when you are finished, and when you are not watching.
- Use care when opening oven door. Let hot air or steam escape before removing or replacing food.
- Always position oven rack(s) in desired location while oven is cool.
- Do not store flammable materials on or near the range. They could explode or burn.
- Do not store things children might want above the range. Children could be burned or injured while climbing on it.
- Do not leave children alone or unattended in area where the range is in use. They should never be allowed to sit or stand on any part of the range. They could be burned or injured.
- Never use a match or other flame to look for a gas leak. Explosion and injury could result.
- Know where your main gas shut off valve is located.
- Keep range vents unobstructed.
- Clean your range regularly. See care and cleaning instructions in this manual.
- Be sure all range parts are cool before cleaning.
- Do not clean door heat seal. It is essential for a good seal. Care should be taken not to rub, damage, or move the seal. Clean only parts recommended in this Use and Care Guide.
- Do not repair or replace any part of the range unless specifically recommended in this manual. All other servicing should be referred to a qualified technician.
- Disconnect the electrical supply before servicing the range.

**- SAVE THESE INSTRUCTIONS -**

# Using Your Range

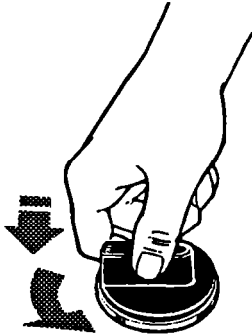

Surface burner marker

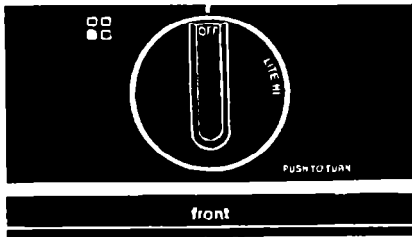

## Using the surface burners

Control knobs must be pushed In, then turned to the LITE position. The clicking sound is the ignition sparking.

To stop the clicking sound after the burner lights, turn the control knob back to a desired setting. The control knob can be set anywhere between HI and OFF.

### Surface burner markers

The solid dot in the surface burner marker shows which surface burner is turned on by that knob.

**Until you get used to the settings, use the following as a guide.** For best results, start cooking at the high settings; then turn the control knob down to continue cooking.

**Use LITE** to light the burner. After the burner lights, turn control back to a desired setting to stop the clicking of the ignition.

**Use HI** to start foods cooking; to bring liquids to a boil.

**Use a medium setting** to continue cooking or to fry chicken or pancakes; for gravy, pudding and icing; to cook large amounts of vegetables.

**Use a low setting** to keep food warm until ready to serve.

**NOTE:** Do not cook with the control in the LITE position.

### In case of a prolonged power failure:

Surface burners can be manually lighted. Hold a lighted match near a burner and turn the control to the LITE position. After the burner lights, turn the control to the desired setting.

## ⚠ WARNING

### Burn, Fire and Explosion Hazard

- Burner flame should not extend beyond the edge of the cooking utensil. The flame can burn you and cause poor cooking results.
- Be sure all control knobs are turned to OFF when you are not cooking. Someone could be burned or a fire could start if a burner is accidentally left ON.
- If the flame should go out while cooking, or if there is a strong gas odor, turn the burners OFF. Wait five minutes for the gas odor to disappear, before relighting burner. If gas odor is still present, see safety note on page 3. Failure to follow these precautions could result in explosion or fire.
- Do not attempt to light the oven burner during a power failure. Personal injury could result.

## Setting the clock

Push in and turn the Minute Timer Knob to set the clock.

1. Push In Minute Timer Knob and turn clockwise until clock shows the correct time of day.

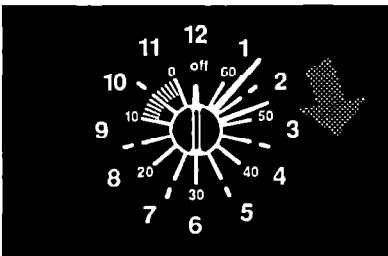
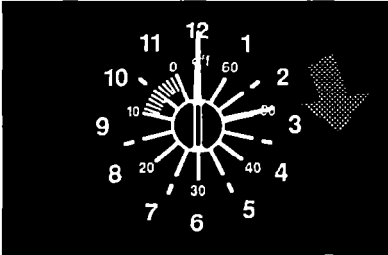

2. Let the Minute Timer Knob pop out. Turn clockwise until Minute Timer hand points to OFF. The clock setting will change if you push in the knob when turning.

## Using the Minute Timer

The Minute Timer does not start or stop the oven. It works like a kitchen timer. Set it in minutes up to an hour. You will hear a buzzer when the set time is up.

**Do not push in the knob when setting the Minute Timer.**

1. Without pushing it in, turn the Minute Timer Knob counterclockwise until the timer hand passes the setting you want.

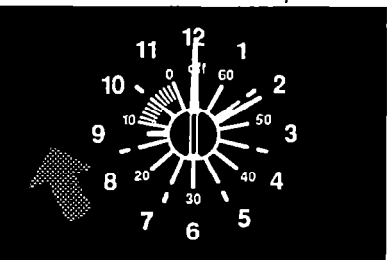
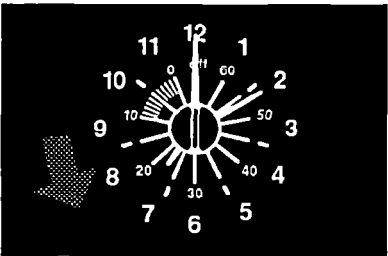

2. Without pushing it in, turn the knob back to the setting you want. When the time is up, a buzzer will sound. To stop the buzzer, turn the Minute Timer hand to OFF.

**NOTE:** Pushing in and turning the Minute Timer Knob changes the clock setting.

## Using the oven control

### Baking/roasting

1. Position the rack(s) properly **before** turning on the oven. **To change rack position**, pull rack out to stop, raise front edge and lift out.

When using one rack, the rack should be placed so the top of the food will be centered in the oven. Always leave at least 1 1/2 to 2 inches (4-5 cm) between the sides of the pan and the oven walls and other pans. For more information, see the Cooking Guide.

2. Push in and turn the Oven Temperature Control Knob to the baking temperature you want. The oven burner will automatically light in 50-60 seconds.
3. When baking, preheat the oven for 10 minutes. (Preheating is not needed when roasting.) Put food in the oven.

**NOTE:** Do not place food directly on the oven bottom.

4. During baking/roasting, the oven burner will turn on and off to maintain the temperature setting.
5. When baking/roasting is done, turn the Oven Temperature Control Knob to OFF.

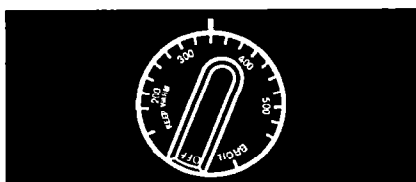

oven temp

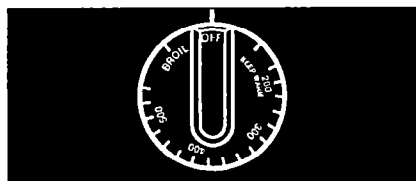

oven temp

**Adjusting the oven temperature control**

Does your oven seem hotter or colder than your old oven? The temperature of your old oven may have shifted gradually without you noticing the change. Your new oven is properly adjusted to provide accurate temperatures. But, when compared to your old oven, the new design may give you different results.

If, after using the oven for a period of time, you are not satisfied with the temperature settings, they can be adjusted by following these steps:

1. Turn the Oven Temperature Control Knob to the off position. Pull knob straight off and flip it over so the back matches the illustration in Step 2.

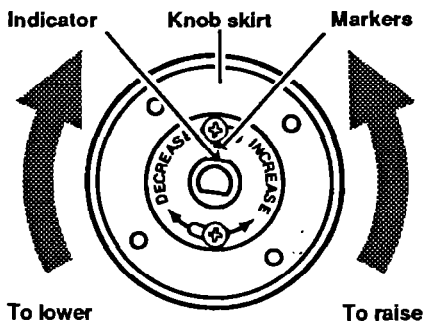
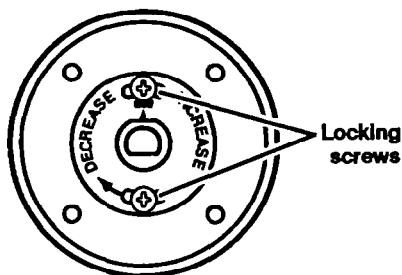

2. Loosen the locking screws. Note the position of the indicator.

3. To lower the temperature, hold knob handle firmly and turn knob skirt clockwise to move the indicator one marker line to the left. Each line equals about 10°F (5°C).

4. To raise the temperature, hold knob handle firmly and turn knob skirt counterclockwise to move the indicator one marker line to the right. Each line equals about 10°F (5°C).

Tighten the locking screws and replace the control knob.

## Using Your Range Continued

---

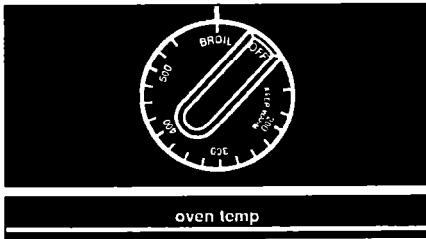
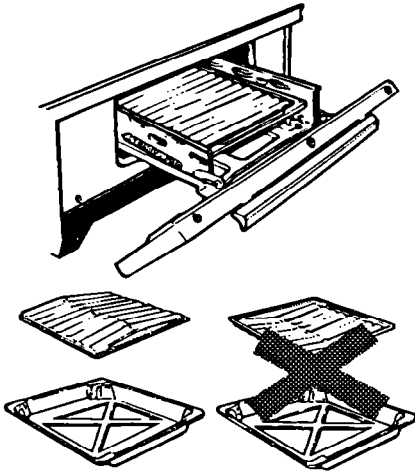

### Broiling

The broiler drawer is located below the oven door. **Always broil with the oven door closed.**

1. Pull the broiler drawer open and tilt the door panel down.
2. Place broiler pan grid so grease can drain down sides into lower part of broiler pan. See picture.
3. Before the broiler is turned on, place food on broiler pan and position the broiler pan at one of the three levels. Refer to a reliable cookbook for broiling chart.
4. Push in and turn the Oven Temperature Control Knob to BROIL. The broiler will automatically light in 50-60 seconds.
5. When broiling is done, turn the Oven Temperature Control Knob to OFF.

## Using the griddle or fifth surface burner

### **⚠ WARNING**

**Burn, Fire and Product Damage Hazard**

- Be sure the griddle/fifth burner control is off and the griddle is cool and covered when not in use. Failure to do so could result in burns, fire or damage.
- When cleaning griddle, never use a metal scouring pad or abrasive cleanser on the griddle. These will damage the non-stick surface.
- Do not use cookware on the griddle. Use only plastic or nylon kitchen utensils on the griddle. Metal can damage the non-stick cooking surface.

**Before using the griddle for the first time:**

1. The cooking surface should be washed with warm, soapy water, rinsed and dried.
2. After cleaning, lightly wipe the cooking surface with cooking oil to prevent food from sticking. You don't have to season (grease) the griddle every time you use it. Be sure to use only cooking oil (not shortening or butter) to season the griddle.
3. Preheat on HI, then turn control to a lower setting to cook.
4. Place food directly on cooking surface.
5. Turn off the griddle burner when cooking is finished. Leaving burner ON will damage the griddle.

**Griddle chart**

Preheat on HI, then turn to a lower setting to cook.

FOOD	PREHEAT TIME	COOK SETTING	APPROXIMATE COOKING TIME	
			SIDE 1	SIDE 2
Bacon	No preheat	Med.	3 Min.	3 Min.
Pancakes	5 Min.	Med.	1 1/2 Min.	1 Min.
Pork sausage patty	No preheat	Med.	4 Min.	3 1/2 Min.
Eggs	No preheat	Med.	1 1/2 Min.	1 Min.
Grilled Sandwiches	5 Min.	Med.	3 Min.	3 Min.
French Toast	5 Min.	Med.	3 Min.	3 Min.

Griddling times are approximate and may need to be adjusted to individual tastes.

## Using Your Range Continued

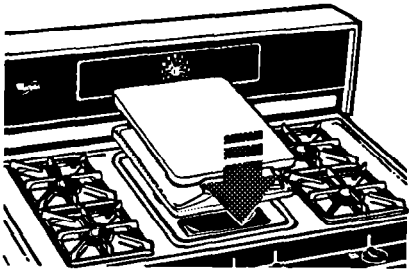
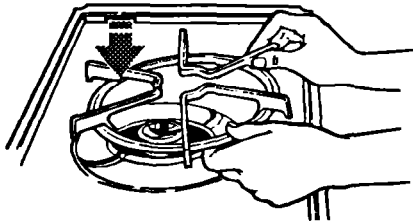
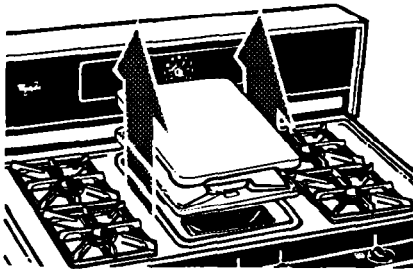
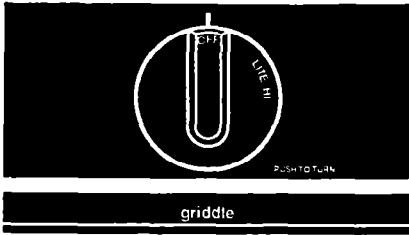

### Using the fifth surface burner

1. Make sure the Griddle/Fifth Burner Control Knob is turned to OFF and the griddle is cool.

2. Remove the griddle cover and griddle from the cooktop.

3. Install the fifth burner assembly and grate. Use this burner as you would any other surface burner. (See control setting guide on page 6.)

4. After cooking is complete and fifth burner grate is cool, remove the grate and install the griddle and griddle cover. Store the grate in the storage compartment or a convenient place.

## The oven vent

Hot air and moisture escape from the oven through a vent just under the backguard. The vent is needed for air circulation. **Do not block the vent.** Poor baking/roasting will result.

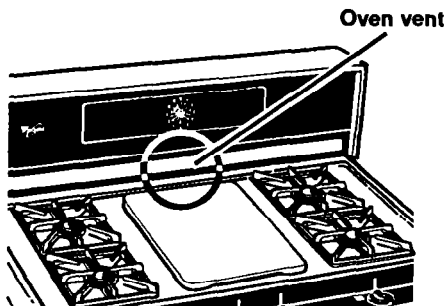

### **▲WARNING**

#### **Burn Hazard**

When the oven is ON, pans and pan handles left near the oven vent can become hot enough to burn the user and to melt plastics. Use potholders to move pans. Never store plastics, paper or other items that could melt or burn near the oven vent, or any of the surface burners.

# Caring For Your Range

## ⚠ WARNING

### Burn, Electrical Shock, Fire and Explosion Hazard

- Make sure all controls are OFF and the range is cool before cleaning.
- Do not use oven cleaners, bleach or rust removers.
- Do not use gasoline or other flammable liquids or vapors to clean this or any other appliance.
- Keep the appliance area clear and free from combustible materials, gasoline and other flammable vapors and liquids.
- Do not obstruct the flow of combustion and ventilation air.

Failure to follow these guidelines could result in burns, electrical shock, fire or explosion.

## Control panel and knobs

1. Make sure all control knobs are turned off.
2. Pull control knobs straight off.
3. Use warm, soapy water or spray glass cleaner and a soft cloth to wipe the control panels. Rinse and wipe dry with a soft cloth.
4. Wash control knobs in warm, soapy water. Rinse well and dry with a soft cloth. Do not soak.

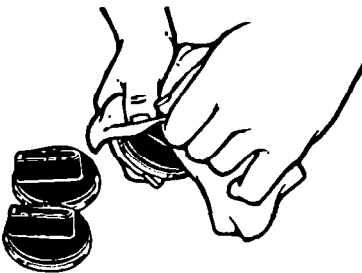
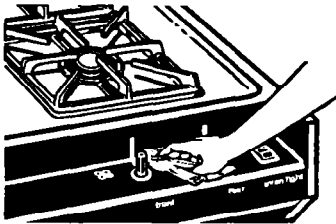
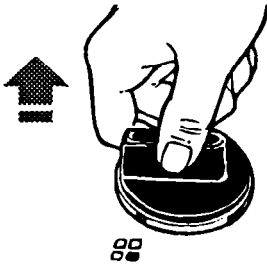

**Caring For Your Range  
Continued**

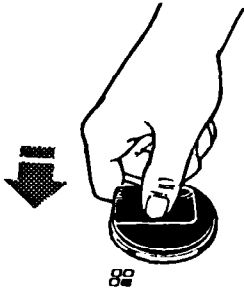

5. Replace control knobs by pushing them firmly into place.

**NOTE:** When cleaning, never use steel wool, abrasives, or commercial oven cleaners which may damage the finish. After cleaning, make sure all control knobs point to OFF.

## Surface burner grates, reflector pans and griddle

1. Make sure all surface burners are off and the surrounding parts are cool.

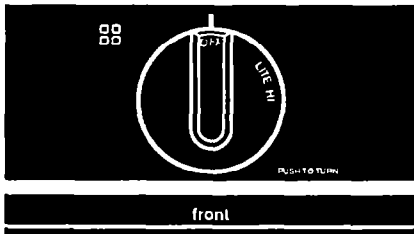

2. Lift off the burner grates, reflector pans and/or griddle and cover.

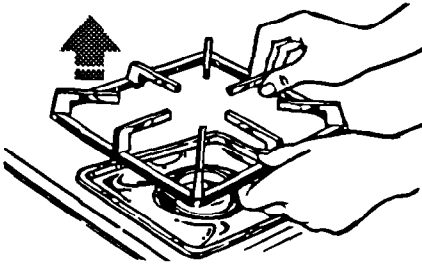

3. Wash the grates and reflector pans with warm, soapy water or in a dishwasher. Wash the griddle and cover with warm, soapy water. Use a nonabrasive plastic scouring pad for heavily soiled areas. Rinse and dry well.

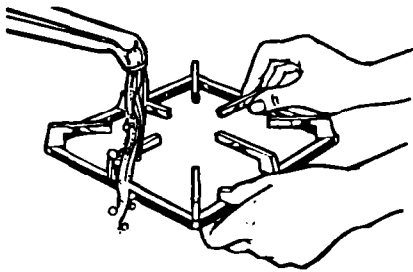

4. Replace reflector pans, burner grates and/or griddle and cover.

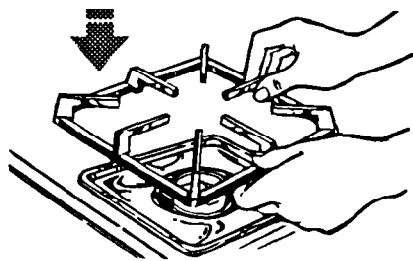

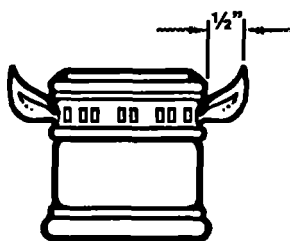
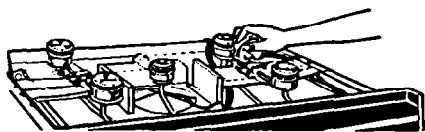

Typical surface burner flame

## Surface burners

Remove the cooktop, following instructions under "Removable cooktop" below.

Wipe off surface burners with warm, soapy water and a soft cloth after each use.

Occasionally check the burner flames for proper size and shape as shown. A good flame is blue in color. If flames lift off ports, are yellow, or are noisy when turned off, you may need to clean the burners (see "Cleaning tips" on page 18), or call a qualified technician for adjustment.

## Removable cooktop

1. Remove surface burner grates and reflector pans. Also remove griddle cover, griddle and insert (under griddle).

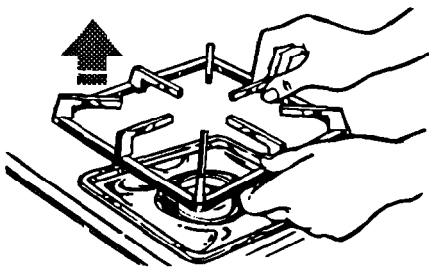

2. Lift front of cooktop enough to clear front of range. Grasp both sides of the cooktop, lift and pull forward to remove.

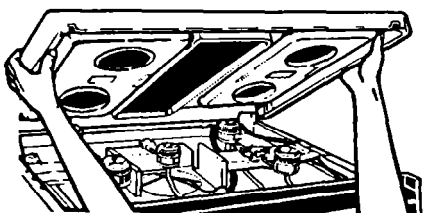

## Caring For Your Range Continued

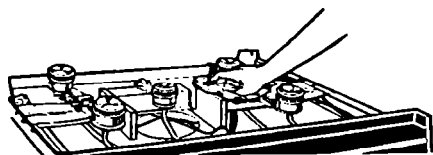

3. Wipe surface under the cooktop with warm, soapy water. Use a soap-filled plastic scrubbing pad on heavily soiled areas.
4. Replace cooktop by fitting studs on back of cooktop into guide holes in rear vertical supports. Lower front of cooktop. Avoid hitting the control panel. Replace reflector pans, surface burner grates, insert, griddle and griddle cover.

### **⚠ WARNING**

- **Personal Injury and Product Damage Hazard**
- Do not try to clean under the cooktop without removing it first. The cooktop could accidentally fall and injure you.
- Do not drop the cooktop. Damage can result to porcelain and the cooktop frame.

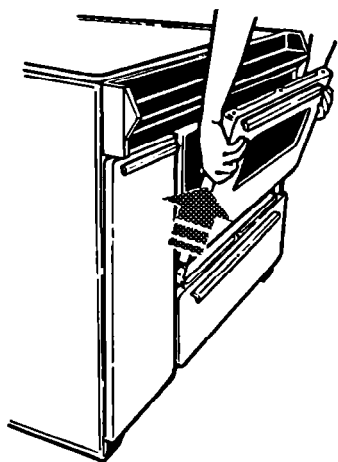

## Removable oven door

Removing the oven door will help make it easier to clean the oven.

### **⚠ WARNING**

- **Burn and Electrical Shock Hazard**
- Make sure all controls are OFF and the oven is cool before removing oven door. Failure to do so can result in burns or electrical shock.

1. Open the door to the first stop position.
2. Hold the door at both sides and lift it at the same angle it is in.
3. **To replace**, fit the bottom corners of the door over the ends of the hinges.  
Push the door down evenly. The door will close only when it is on the hinges correctly.

## Using the standard-cleaning oven

The standard-cleaning oven has to be hand-cleaned. Use warm, soapy water, soapy steel wool pads or a commercial oven cleaner. See "Cleaning tips" on page 18 for further instructions.

### Using foil

To catch sugar or starchy spills from pies and casseroles, use a piece of heavy-duty aluminum foil or a shallow pan on the lower rack, slightly larger than the cooking container.

### **⚠ WARNING**

#### **Burn and Product Damage Hazard**

- **Make sure all controls are OFF and the oven is cool before using foil. Failure to do so can result in burns.**
- **Do not use foil to cover oven floor or to completely cover a rack. Good air circulation is needed for the oven to operate properly. Poor cooking results could occur.**
- **Do not allow commercial oven cleaner to contact the heat seal, thermostat or exterior surfaces of the oven. Damage will occur.**

1. Turn off all controls.
2. Put foil or pan under the cooking container. Make sure the foil is centered and large enough to catch any spill-overs.

## Caring For Your Range Continued

### Cleaning tips

#### Control knobs

Clean with warm, soapy water and a soft cloth.

- Wash, rinse and dry well.
- Do not soak.

#### Control panels

Clean with warm, soapy water or spray glass cleaner and a soft cloth.

- Wash, rinse and dry well.
- Follow directions provided with the cleaner.

#### Exterior surfaces (other than control panels)

Clean with warm, soapy water and a soft cloth.

- Wipe off regularly when cooktop and oven are cool.

Use a nonabrasive plastic scrubbing pad for heavily soiled areas.

- Do not use abrasive or harsh cleaners.

**NOTE:** Do not allow food containing acids (such as vinegar, tomato or lemon juice) to remain on surface. Acids may remove the glossy finish.

Also, wipe up milk or egg spills when cooktop is cool. Be careful when cleaning around model and serial number plate; the numbers wipe off easily.

#### Surface burners

Clean with warm, soapy water and a soft cloth.

- Remove cooktop (see page 15).
- Wipe off spills immediately after burner has cooled.

#### For cooked-on food:

- Remove burner from manifold with Phillips screwdriver.
- Wash with warm, soapy water and a nonabrasive plastic scrubbing pad.
- Rinse and dry well.
- If ports are clogged, clean with a straight pin. **Do not enlarge or distort port. Do not use a wooden toothpick.**
- Do not clean surface burner in dishwasher.

#### Surface burner grates and chrome reflector pans

Clean with warm, soapy water and a nonabrasive plastic scrubbing pad.

- Wash, rinse and dry well.

#### OR

Clean in a dishwasher.

#### Griddle, drip pan and cover

Clean with warm, soapy water and a soft cloth or nonabrasive plastic scrubbing pad.

- Clean after each use.
- Remove griddle and drip pan (located under the griddle) to wash, rinse and dry well.
- **Do not use metal scouring pads or harsh cleansers.**
- Use a nonabrasive plastic scrubbing pad for cooked-on food.

#### Broiler drawer, pan and grid

Clean with warm, soapy water and a nonabrasive plastic scrubbing pad.

- Clean after each use.
- Wash pan and grid. Rinse and dry well.
- **After broiler is cool**, wipe interior with warm, damp cloth. For cooked-on food, use a nonabrasive plastic scrubbing pad.

#### Oven racks

Clean with warm, soapy water or soapy steel wool pads.

- Wash, rinse and dry. Use soapy steel wool pads for heavily soiled areas.

#### Oven door glass

Use spray glass cleaner or warm, soapy water and a nonabrasive plastic scrubbing pad.

- Make sure oven is cool.
- Follow directions provided with the cleaner.
- Wash, rinse and dry well.

#### Standard-cleaning oven

Clean with warm, soapy water or soapy steel wool pads.

- Make sure oven is cool.
- Remove door for easier access.
- Clean heavily soiled areas or stains. Rinse well with water.

#### OR

Use commercial oven cleaners.

- Remove door for easier access.
- Place newspaper on floor to protect floor surface.
- Follow directions provided with the oven cleaner.
- Rinse well with clear water.
- Use in well-ventilated room.
- **Do not allow commercial oven cleaners to contact the heat seal, thermostat or exterior surfaces of the range. Damage will occur.**

Place piece of heavy-duty aluminum foil or shallow pan, slightly larger than the cooking container, on lower rack to catch spill-overs.

## Using and replacing the light bulbs

### The cooktop light

The fluorescent light is on the bottom of the control panel. The Cooktop Light Switch is located on the left side of the front control panel.

### **⚠ WARNING**

**Electrical Shock and Burn Hazard**  
**Make sure power to the range has been disconnected at the main power supply and that all surface burners are OFF and cool. Failure to do so could result in electrical shock or burns.**

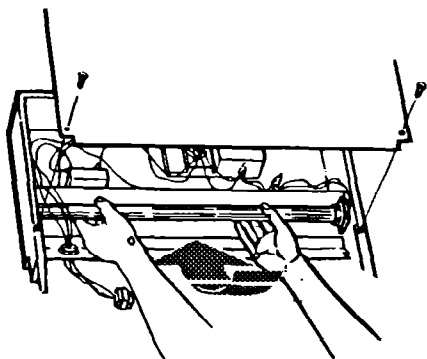
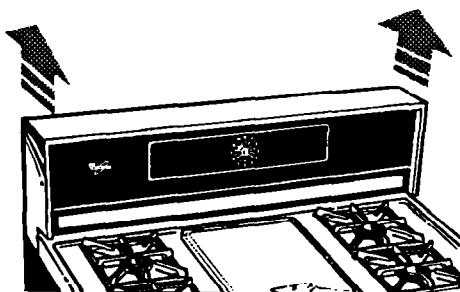

### To replace the cooktop light:

1. Turn off the control knobs and unplug appliance or disconnect at the main power supply.
2. Lift up the cooktop and disconnect the electrical plug to the backguard. Lower the cooktop.
3. Grasp each side of the backguard and lift it straight up.
4. Turn backguard over. Remove the four screws holding the back cover panel, then remove the cover.
5. Roll bottom of fluorescent tube away from you until both ends can be removed from the receptacles. Replace with a 20-watt cool-white fluorescent tube.
6. Replace the back cover panel and screws.
7. Replace the backguard. Reconnect the electrical plug under the cooktop.
8. Plug in appliance or reconnect at the main power supply.

### The oven light

The oven light will come on when you push the Oven Light Switch on the control panel. Push the switch again to turn off the light.

## **⚠ WARNING**

### **Electrical Shock and Personal Injury Hazard**

- **Make sure oven and light bulb are cool and power to the oven has been turned off before replacing the light bulb. Failure to do so could result in electrical shock or burns.**
- **Be careful not to drop the bulb. Broken glass could cause injury.**

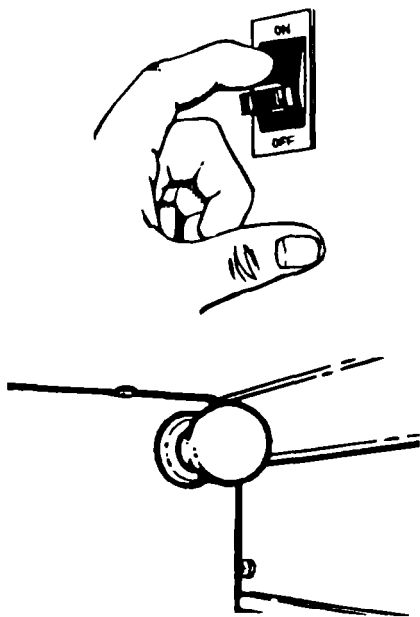

### To replace the oven light:

1. Unplug appliance or disconnect at the main power supply.
2. Remove the light bulb from its socket. Replace with a 40-watt appliance bulb. Plug in appliance or reconnect at the main power supply.

# If You Need Service Or Assistance...

## We suggest you follow these steps:

### 1. Before calling for assistance ...

Performance problems often result from little things you can find and fix without tools of any kind.

#### If nothing operates:

- Is the gas turned on?
- Is the power supply cord plugged into a live circuit with the proper voltage? (See Installation Instructions.)
- Have you checked your home's main fuses or circuit breaker box?
- Have instructions in this book been followed?
- Is the control knob set in the correct position?
- Is the flow of combustion and/or ventilation air to the unit obstructed? **Do not obstruct airflow to and around unit.**
- Recheck suspected defect.

#### If burner fails to light:

- Is the range connected to electrical power?
- Have you checked your home's main fuses or circuit breaker box?
- Are burner ports clogged? See page 18.

#### If burner flames are uneven:

- Are burner ports clogged? See page 18.

#### If burner flames lift off ports, are yellow, or are noisy when turned off:

- The air/gas mixture may be incorrect. (Call for service.)

#### If burner makes a popping noise when ON:

- Is the burner wet from washing? Let dry.

#### If control knob(s) will not turn:

- Did you push in before trying to turn?

#### If cooking results are not what you expected:

- Is the range level?
- Does the oven temperature seem too low or too high? See page 9.
- If needed, have you preheated the oven as the recipe calls for?
- Does the flame size fit the cooking utensil being used? (See the Cooking Guide.)
- Are you following a tested recipe from a reliable source?
- Are you using pans recommended in the Cooking Guide?
- If baking, have you allowed 1 1/2 to 2 inches (4-5 cm) on all sides of the pans for air circulation?
- Are the pans the size called for in the recipe?
- Do the cooking utensils have smooth, flat bottoms and fit the surface burners being used?

See the Cooking Guide for more information on cooking problems and how to solve them.

## If You Need Service Or Assistance Continued

### 2. If you need assistance\* ...

Call Whirlpool Consumer Assistance Center telephone number. Dial free from anywhere in the U.S.:

**1-800-253-1301**

and talk with one of our trained consultants. The consultant can instruct you in how to obtain satisfactory operation from your appliance or, if service is necessary, recommend a qualified service company in your area.

If you prefer, write to:

Mr. Donald Skinner  
Director of Consumer Relations  
Whirlpool Corporation  
2000 M-63  
Benton Harbor, MI 49022

Please include a daytime phone number in your correspondence.

### 3. If you need service\* ...



Whirlpool has a nationwide network of authorized Whirlpool<sup>SM</sup> service companies. Whirlpool service technicians are trained to fulfill the product warranty

and provide after-warranty service, anywhere in the United States. To locate the authorized Whirlpool service company in your area, call our Consumer Assistance Center telephone number (see Step 2) or look in your telephone directory Yellow Pages under:

APPLIANCES - HOUSEHOLD - MAJOR - SERVICE & REPAIR      ELECTRICAL APPLIANCES - MAJOR - REPAIRING & PARTS

OR

WASHING MACHINES, DRYERS & IRONERS - SERVICING

WHIRLPOOL APPLIANCES  
AUTHORIZED WHIRLPOOL SERVICE

SERVICE COMPANIES  
XYZ SERVICE CO  
123 Maple.....999-9999

### 4. If you need FSP<sup>®</sup> replacement parts\* ...

FSP is a registered trademark of Whirlpool Corporation for quality parts. Look for this symbol of quality whenever you need a replacement part for your Whirlpool appliance. FSP replacement parts will fit right and work right, because they are made to the same exacting specifications used to build every new Whirlpool appliance.

To locate FSP replacement parts in your area, refer to Step 3 above or call the Whirlpool Consumer Assistance Center number in Step 2.

### 5. If you are not satisfied with how the problem was solved\* ...

- Contact the Major Appliance Consumer Action Panel (MACAP). MACAP is a group of independent consumer experts that voices consumer views at the highest levels of the major appliance industry.
- Contact MACAP only when the dealer, authorized servicer or Whirlpool has failed to resolve your problem.  
Major Appliance Consumer Action Panel  
20 North Wacker Drive  
Chicago, IL 60606
- MACAP will in turn inform us of your action.

\* When requesting assistance, please provide: model number, serial number, date of purchase, and a complete description of the problem. This information is needed in order to better respond to your request.



# WHIRLPOOL®

## Gas Cooking Product Warranty

GR003

LENGTH OF WARRANTY	WHIRLPOOL WILL PAY FOR
<b>FULL ONE-YEAR WARRANTY</b> <i>From Date of Purchase</i>	FSP® replacement parts and repair labor to correct defects in materials or workmanship. Service must be provided by an authorized Whirlpool <sup>SM</sup> service company.
<b>WHIRLPOOL WILL NOT PAY FOR</b>	
<p><b>A. Service calls to:</b></p> <ol style="list-style-type: none"> <li>1. Correct the installation of the cooking product.</li> <li>2. Instruct you how to use the cooking product.</li> <li>3. Replace house fuses or correct house wiring or plumbing.</li> <li>4. Replace owner accessible light bulbs.</li> </ol> <p><b>B. Repairs when the cooking product is used in other than normal, single-family household use.</b></p> <p><b>C. Pick-up and delivery.</b> This product is designed to be repaired in the home.</p> <p><b>D. Damage to the cooking product caused by accident, misuse, fire, flood, acts of God or use of products not approved by Whirlpool.</b></p> <p><b>E. Repairs to parts or systems caused by unauthorized modifications made to the appliance.</b></p>	

WHIRLPOOL CORPORATION SHALL NOT BE LIABLE FOR INCIDENTAL OR CONSEQUENTIAL DAMAGES. Some states do not allow the exclusion or limitation of incidental or consequential damages so this limitation or exclusion may not apply to you. This warranty gives you specific legal rights, and you may also have other rights which vary from state to state.

Outside the United States, a different warranty may apply. For details, please contact your authorized Whirlpool distributor or military exchange.

If you need service, first see the "Service and Assistance" section of this book. After checking "Service and Assistance," additional help can be found by calling our Consumer Assistance Center telephone number, 1-800-253-1301, from anywhere in the U.S.

® Registered Trademark/SM Service Mark of Whirlpool Corporation